

SENT-Simulyzer

(Original operating instructions)



SENT-Simulyzer operating instructions

Copyright

© Seskion GmbH 2023

All rights reserved, including with regard to any disposal, exploitation, reproduction, processing, distribution, as well as in the event of applications for industrial property rights.

Binding nature

The data provided is only intended to describe the product and should not be understood as guaranteed features in the legal sense. The content of the documentation and delivery options for the products are subject to change.

SENT-Simulyzer operating instructions

1	Regarding these operating instructions.....	5
1.1	Issues of this documentation	5
1.2	Scope.....	5
1.3	Further documentation.....	5
1.4	Customer feedback	5
1.5	Presentation of information.....	5
1.5.1	Safety instructions	5
1.5.2	Warnings.....	5
1.5.3	Figures and drawings.....	6
1.5.4	Text emphasis	6
1.5.5	Abbreviations.....	7
2	Safety provisions	8
2.1	Principles.....	8
2.2	Proper use	8
2.3	Improper use	8
2.4	Safety instructions.....	8
2.5	Personnel qualification.....	8
2.6	Operational safety.....	8
3	Warranty.....	9
4	Scope of supply and identification.....	9
4.1	Scope of supply.....	9
5	Overview.....	10
5.1	Functional description.....	10
5.2	Interfaces.....	11
5.2.1	SD card slot	11
5.2.2	USB.....	11
5.2.3	External power supply.....	11
5.2.4	CAN	11
5.2.5	Sensor/ECU IO.....	12
5.2.6	Analog/Digital IO	13
5.2.7	Block diagram SENT power supply and SENT data.....	14
5.3	Display elements.....	15
5.4	Operating modes	16
5.4.1	ECU mode	16
5.4.2	Sensor-Mode	17
5.4.3	Passiv-Mode	18

SENT-Simulyzer operating instructions

6	Technische Daten	19
6.1	Produkt	19
6.2	Environmental conditions.....	19
7	Measurement accuracies	20
8	Transportation and storage	21
8.1	Transportation.....	21
8.2	Storage	21
9	Installation and commissioning	22
9.1	Installation.....	22
9.2	Commissioning	22
12	Assistance in the event of faults	23
13	Disposal.....	24
13.1	Recycling.....	24
13.2	Significant components.....	24
13.3	Packaging	24
13.4	Disposal by the manufacturer	24
14	Appendix.....	25
14.1	Service address.....	25
14.2	Spare and wearing parts.....	25
14.3	Declaration of conformity.....	25

SENT-Simulyzer operating instructions

1 Regarding these operating instructions

1.1 Issues of this documentation

Issue	Last updated	Note
01	2023-12	First issue

Tab. 1 Issue history

1.2 Scope

This documentation applies to all Simulyzers as from version 2.0 with a model code beginning as follows:

Type SENT

1.3 Further documentation

You can find further documentation on our homepage: www.seskion.de in the relevant product selection.

1.4 Customer feedback

Suggestions, wishes, or improvements from our customers are very important to us.

Comments regarding the documentation can be inserted directly in the PDF document and sent to us via email at sales@seskion.de.

1.5 Presentation of information

1.5.1 Safety instructions

The safety instructions in these operating instructions specify hazards which may occur when handling the product. They are listed as continuous text without emphasis.

1.5.2 Warnings

The warnings in these operating instructions contain specific signal words (danger, warning, caution, notice) and a signal graphic.

The signal word should draw attention to the safety instruction and designates the severity of the hazard or the danger of material damage.

The signal graphic (warning triangle with exclamation point) which precedes the signal words danger, warning, and caution indicates hazards to people.



Not observing this warning may result in moderate or minor physical injury.

SENT-Simulyzer operating instructions

The notice signal word on a blue background indicates the risk of material damage.

NOTICE

Not observing this warning may result in material damage.

1.5.3 Figures and drawings

The figures and drawings in these operating instructions are intended to support and clarify the text.

Some of these figures and drawings may contain details and/or configurations which are not present on the product and/or are designed differently. They may also contain components which are not included in the product's scope of supply.

1.5.4 Text emphasis

In order to display the textual information in a comprehensible manner, the following means of emphasizing text are used:



Notice of further documentation



This notice provides you with important information which you should observe.

- First-level list items are indicated with a solid bullet point
 - Second-level list items are indicated with an empty bullet point

Instructions

1. First step of an instruction
2. Second step of an instruction
 - ➔ Result of the second step
3. Third step of an instruction

Notice: This is a notice concerning the third instruction.



Instructions must be performed in the correct order!

SENT-Simulyzer operating instructions

1.5.5 Abbreviations

Abbreviations are used in this documentation. You can see what they mean in the table below

Abbreviation	Meaning
API	Application programming interface
CAN	Controller area network
CRC	Cyclic redundancy check
ECU	Electronic control unit
FPGA	Field-programmable gate array
GND	Ground
NC	Not connected

Tab. 2 Abbreviations

SENT-Simulyzer operating instructions

2 Safety provisions

2.1 Principles

The Simulyzer must only be used if it is in a perfect technical condition.

NOTICE

Use is prohibited if there is visible damage to the interfaces and/or on the housing!

2.2 Proper use

The Simulyzer is only intended for professional use.

Proper use of the Simulyzer consists of fast and easy reading out of sensor data from the SENT bus and peripheral devices as well as transmission of simulation data to control units.

2.3 Improper use

The following cases of misuse are prohibited and resulting damage is excluded from the warranty:

- Operation beyond proper use
- Operation beyond the stipulated technical data, see section 6
- Operation in an environment with spray water

2.4 Safety instructions

The following safety instructions must be observed when handling the Simulyzer:

- Only place the device on a flat surface, a sufficient distance away from falling edges or sufficiently secured against falling.
- Do not operate under the effect of spray water.
- Only operate in vehicles sufficiently secured against acceleration, shock and falling.

2.5 Personnel qualification

The Simulyzer is designed for people in the context of development and testing; among others, these include programmers, system testers, system architects, electronics technicians, and others.

2.6 Operational safety

Each piece of work equipment has to be tested at regular intervals according to the Betriebsicherheitsverordnung (German Industrial Safety Regulation) and as electrical equipment according to DGUV (German Social Accident Insurance) Regulation 3 by an electrician or under their supervision.

This includes the power supply unit provided in the scope of supply.

3 Warranty

All warranty claims shall be voided in the event of improper use and/or incorrect handling. All warranty claims shall also be voided if the Simulyzer is opened independently or attempts to open it are made.

4 Scope of supply and identification

4.1 Scope of supply

The Simulyzer scope of supply consists of the Simulyzer as a product and the following accessories:

- 1x power supply unit
- 1x USB cable
- 2x SUB-D mating connector

SENT-Simulyzer operating instructions

5 Overview

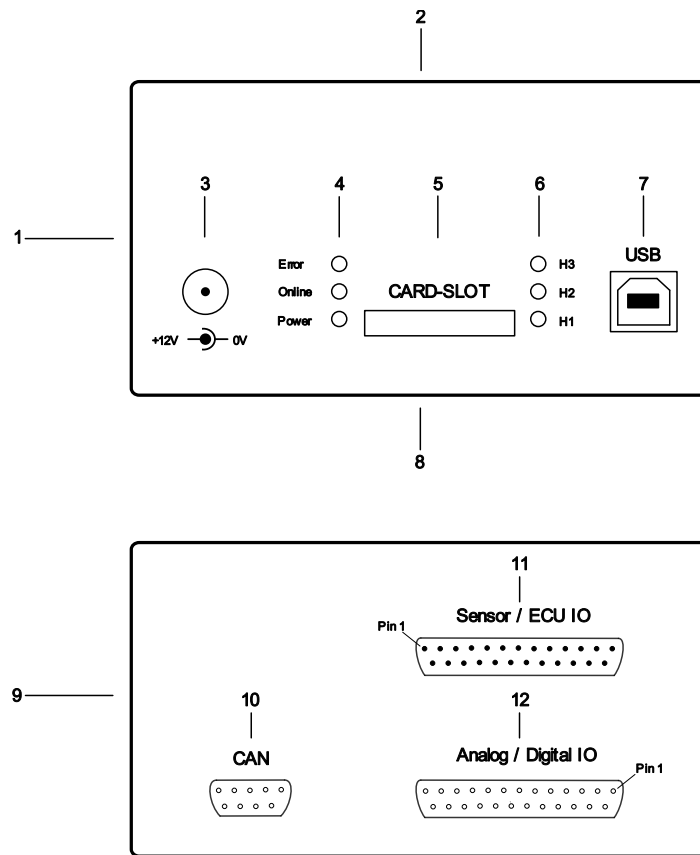

Fig. 1 Overview

- | | |
|---------------------------|------------------------|
| 1 – Front | 7 – USB |
| 2 – Top | 8 – Bottom |
| 3 – External power supply | 9 – Rear |
| 4 – Status display 1 | 10 – CAN |
| 5 – SD card slot | 11 – Sensor/ECU IO |
| 6 – Status display 2 | 12 – Analog/digital IO |

5.1 Functional description

The Simulyzer simulates and/or analyzes data from the SENT bus (for specification see SAE J2716).

Analyzed data can be visualized using the relevant software solution from Seskion. Alternatively, Seskion provides an API which users can independently connect to their system.

SENT-Simulyzer operating instructions

5.2 Interfaces

5.2.1 SD card slot

The SD card slot is intended to expand the storage space for optional recording of measurement data through the use of an SD card.



The SD card is not included in the scope of supply.

5.2.2 USB

The USB 2.0 connection fulfills two functions. On the one hand, it configures the Simulyzer. On the other hand, it transfers measurement data to a PC.

5.2.3 External power supply

This connection is used to connect an external power supply to the Simulyzer.

5.2.4 CAN



The CAN interface is available as standard. However, it must be activated with a license which can be purchased from Seskion.

The CAN interface enables the Simulyzer to be connected to any CAN bus interface.

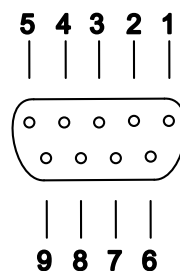

Fig. 2 CAN interface pin assignment

Pin	Assignment
1	NC
2	CAN Low
3	GND
4	NC
5	NC
6	GND
7	CAN High
8	NC
9	NC

Tab. 3 CAN interface pin assignment



The terminating resistor between CAN High and CAN Low is not installed.

SENT-Simulyzer operating instructions

5.2.5 Sensor/ECU IO

Data is exchanged with the SENT sensor bus at the sensor/ECU IO interface.

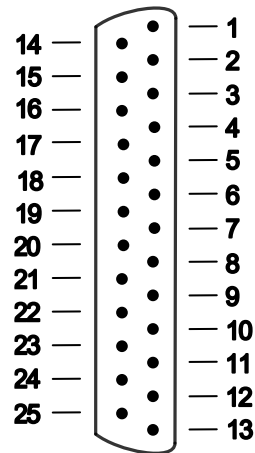

Fig. 3 Sensor/ECU IO - pin assignment

Pin	Assignment
1	VDD1 / ECU 1
2	SENT_DATA 1 / Sensor 1 supply +
3	VDD-Sensor 1 / switched GND DasyiChain1
4	Not Connected
5	Not Connected
6	Not Connected
7	VDD2 / ECU2
8	SENT_DATA 2 / Sensor 2 supply +
9	VDD-Sensor 1 / switched GND DaisyChain 2
10	Not Connected
11	Not Connected
12	Not Connected
13	Not Connected
14	GND
15	GND
16	GND
17	GND
18	Not Connected
19	Not Connected
20	Not Connected
21	Do not connect
22	GND
23	Do not connect
24	GND
25	+12 V

Tab. 4 Sensor/ECU IO - pin assignment

SENT-Simulyzer operating instructions

5.2.6 Analog/Digital IO

General input/output signals are exchanged at the analog/digital IO interface.

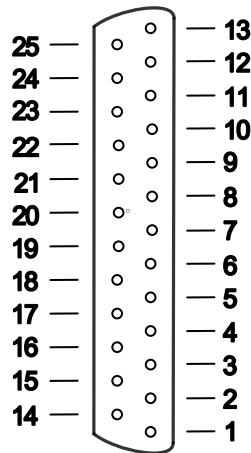

Fig. 4 Analog/Digital IO - pin assignment

Pin	Assignment	Characteristic
1	DAC_1 / Analog Input 1	-10 V...+10 V
2	DAC_2 / Analog Input 2	-10 V...+10 V
3	DAC_3 / Analog Input 3	-10 V...+10 V
4	DAC_4 / Analog Input 4	-10 V...+10 V
5	GND	-
6	DIGE_1 / Digital Input 1	0 V...3,3 V or 5 V (VDDD)
7	DIGE_2 / Digital Input 2	0 V...3,3 V or 5 V (VDDD)
8	DIGE_3 / Digital Input 3	0 V...3,3 V or 5 V (VDDD)
9	DIGE_4 / Digital Input 4	0 V...3,3 V or 5 V (VDDD)
10	DIGE_5 / Digital Input 5	0 V...3,3 V or 5 V (VDDD)
11	DIGE_6 / Digital Input 6	0 V...3,3 V or 5 V (VDDD)
12	DIGA_1 / Digital Output 1	3,3 V or 5 V (VDDD)
13	DIGA_2 / Digital Output 2	3,3 V or 5 V (VDDD)
14	DIGA_3 / Digital Output 3	3,3 V or 5 V (VDDD)
15	DIGA_4 / Digital Output 4	3,3 V or 5 V (VDDD)
16	DIGA_5 / Digital Output 5	3,3 V or 5 V (VDDD)
17	DIGA_6 / Digital Output 6	3,3 V or 5 V (VDDD)
18	VDDDD	3,3 V or 5 V
19	VDDDA	Not Connected
20	AN_OUT1 / Analog Output 1	0 V...+5 V
21	AN_OUT2 / Analog Output 2	0 V...+5 V
22	AN_OUT3 / Analog Output 3	0 V...+5 V
23	AN_OUT4 / Analog Output 4	0 V...+5 V
24	GND	-
25	GND	-

Tab. 5 Analog/Digital IO - pin assignment

SENT-Simulyzer operating instructions

5.2.7 Block diagram SENT power supply and SENT data

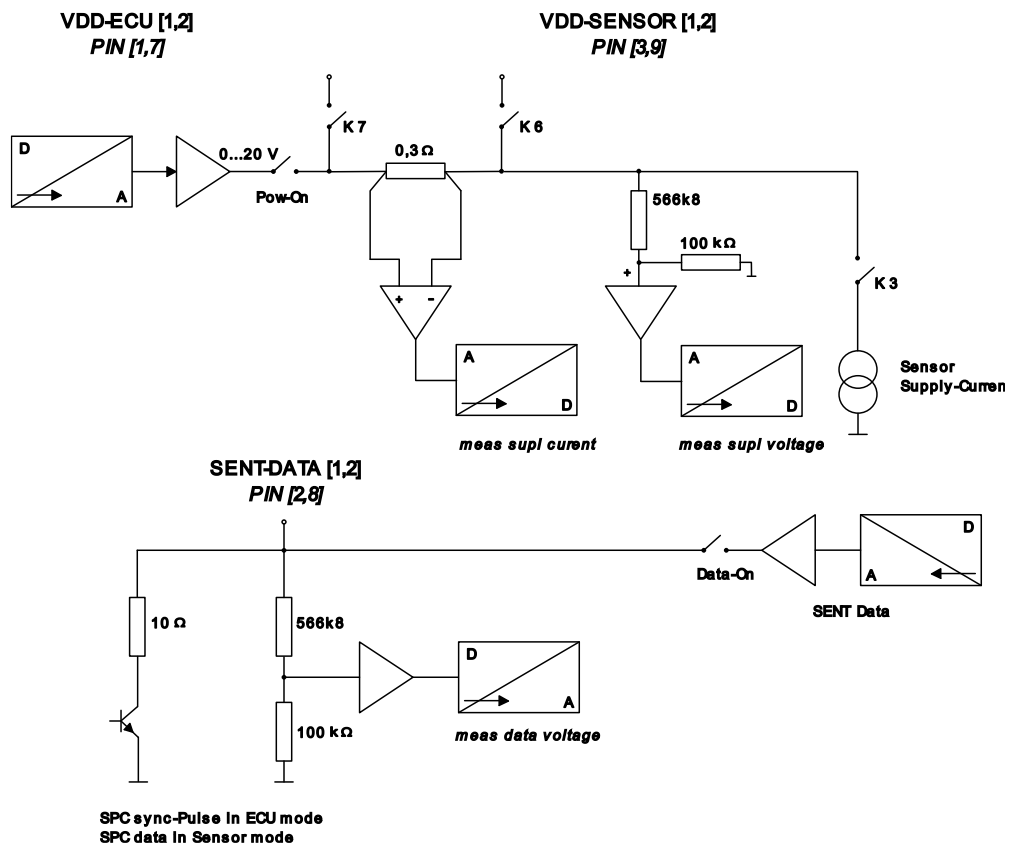

Fig. 5 Blockschaltbild SENT

Mode	K3	K6	K7	Pow-On	Data-Off
Passive	off	on	on	off	off
ECU	off	on	off	on/off	off
Sensor	on	off	on	off	on if not
Simulation	on	off	off	on/off	SPC mode

Tab. 6 Analog/Digital IO - pin assignment

SENT-Simulyzer operating instructions

5.3 Display elements

The display elements are located on the front of the product.

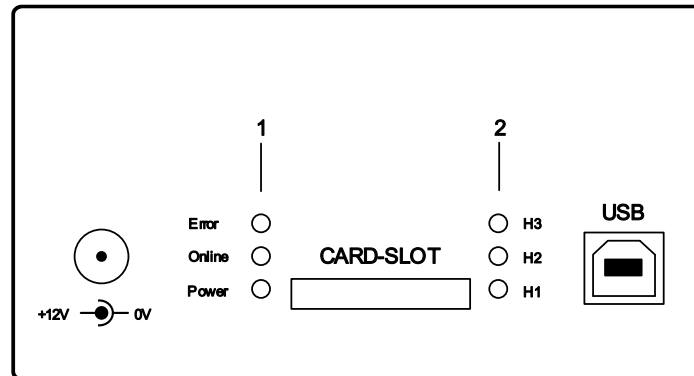

Fig. 6 Display elements

1 – Status display 1

2 – Status display 2

Designation	Color	Status	Designation	Color	Status
Error	Red	Lights up -> error	H3	Yellow	Lights up -> measurement active
Online	Yellow	Lights up yellow -> OK	H2	Yellow	Optional
Power	Green	Lights up yellow -> OK	H1	Yellow	Optional

Tab. 7 Description of display elements

SENT-Simulyzer operating instructions

5.4 Operating modes

 The external power supply must be connected in each operating mode.
 Devices before V2.0 could be operated with USB supply voltage; this is no longer possible.

5.4.1 ECU mode

In "ECU mode", the Simulyzer simulates the ECU and supplies the sensors with power. Data communication between the simulated ECU and the sensors is displayed and recorded.

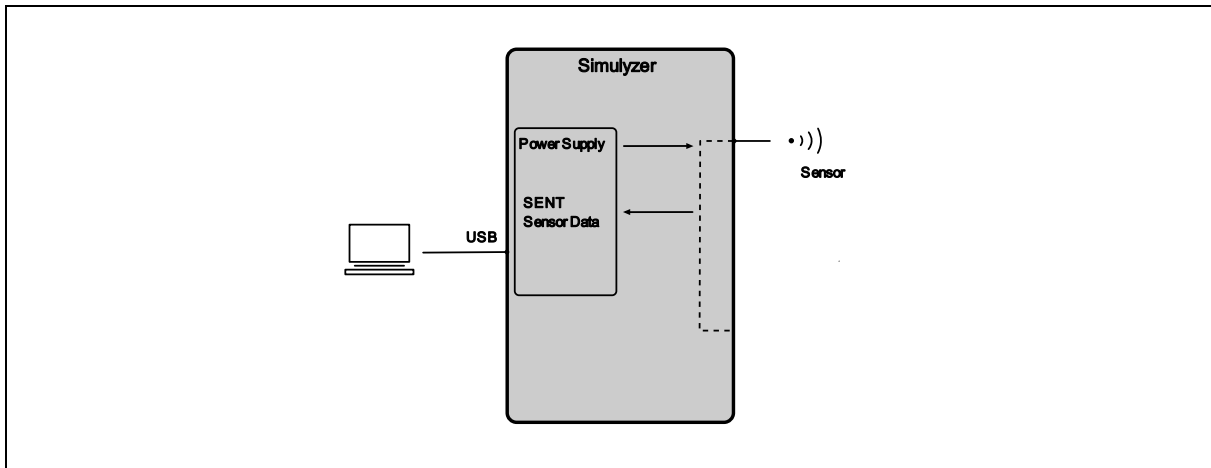

Fig. 7 ECU-Mode

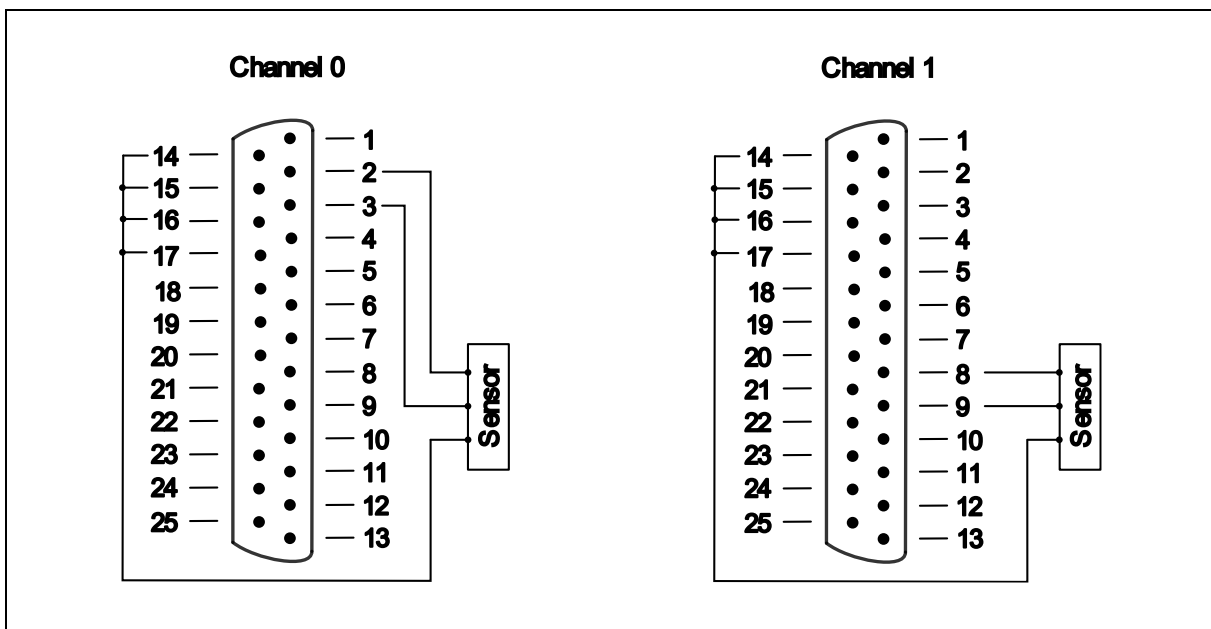

Fig. 8 ECU mode wiring

SENT-Simulyzer operating instructions

5.4.2 Sensor-Mode

In "Sensor mode", the Simulyzer simulates a sensor by generating corresponding data. The data communication between the ECU and the simulated sensor is displayed and recorded.

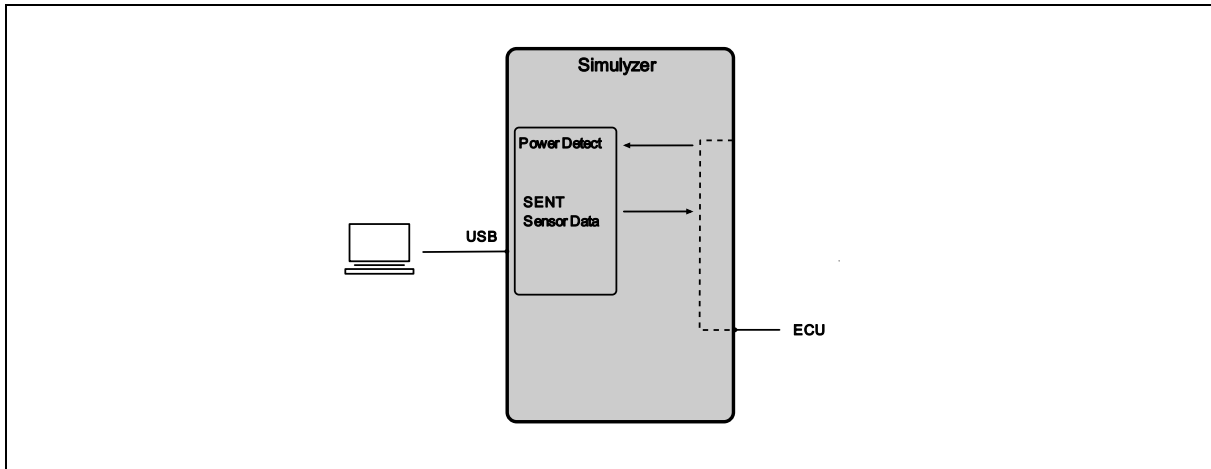

Fig. 9 Sensor-Mode

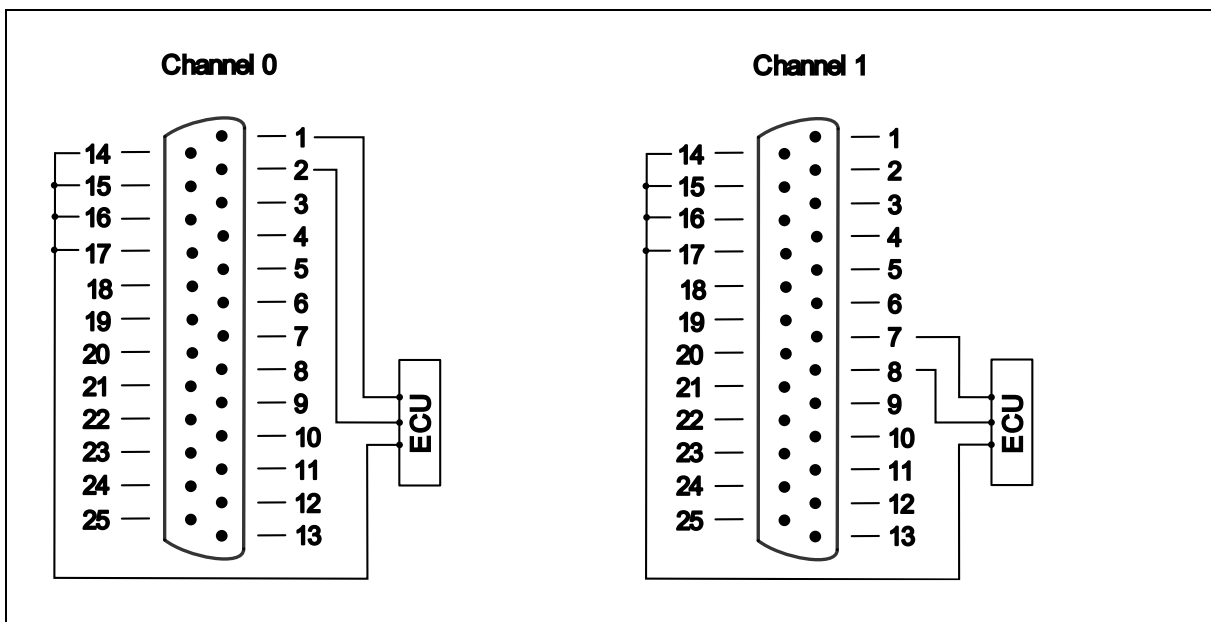

Fig. 10 Sensor mode wiring

SENT-Simulyzer operating instructions

5.4.3 Passiv-Mode

In "Passive mode", the data communication between the ECU and a sensor is displayed and recorded.

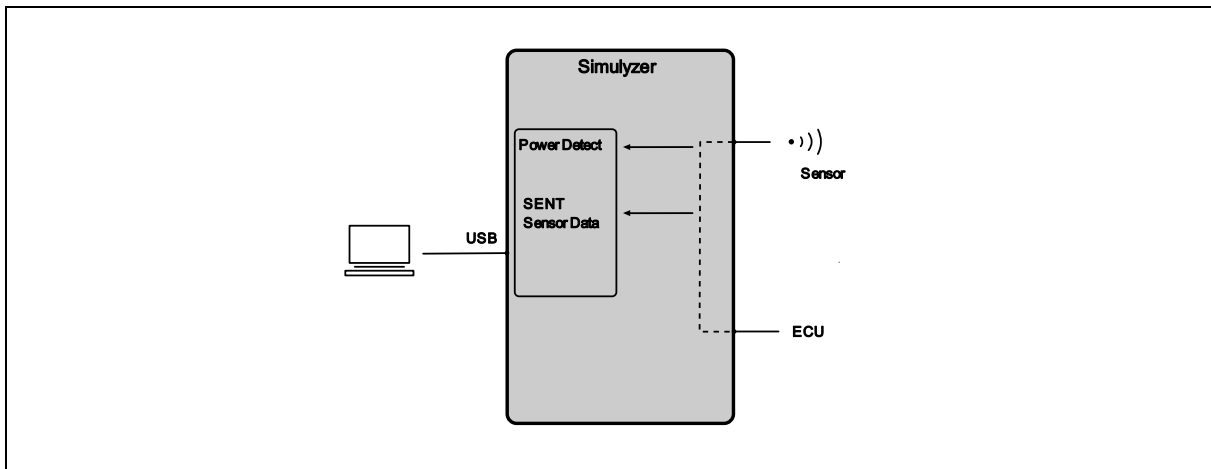

Fig. 11 Passiv-Mode

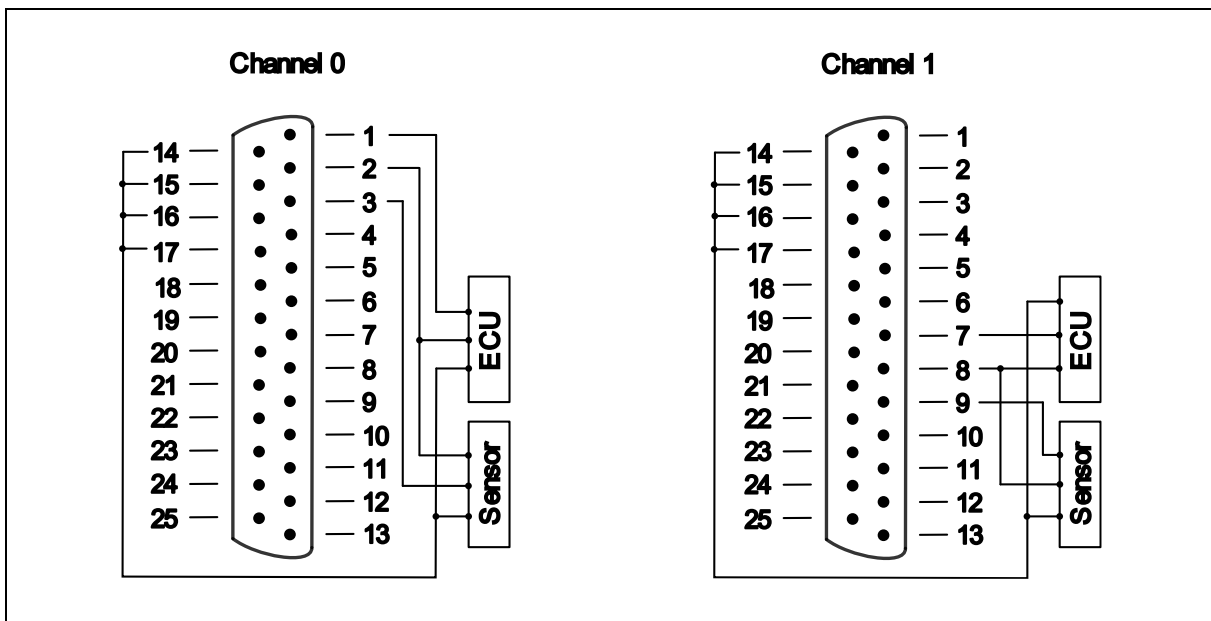

Fig. 12 Passive mode wiring

SENT-Simulyzer operating instructions

6 Technische Daten

6.1 Produkt

NOTICE	Applying external voltages greater than the maximum values specified here may destroy the Simulyzer!
---------------	--

Data	Value
<i>General data</i>	
Dimensions	165 x 105 x 60 mm
Housing material	Aluminum
Weight	1.1 kg
Operating temperature range	0°C to 40°C
Acceleration	Max. 3 g
Relative humidity	Max. 85% non-condensing
<i>Electrical data</i>	
Power consumption	Max. 1 A
Supply voltage for the external sensors in ECU mode	0 V to 20 V

Tab. 8 Technical data – product

6.2 Environmental conditions

The SENT-Simulyzer is only suitable for use under laboratory conditions.

SENT-Simulyzer operating instructions

7 Measurement accuracies

Test condition: ambient temperature 20°C to 26°C

Time base

Measurement	Symbol	Type	Max	Unit	Note
Accuracy of the time base	$\Delta f/f$	± 30	± 50	ppm	-
Aging of the time base	$\Delta f/f_A$	± 5		ppm/year	-
Temperature drift of the time base	$\Delta f/f_T$	± 0.3	± 0.7	ppm/°C	-

Measurements of the supply/data voltages (0 V ... 20 V)

Measurement	Symbol	Type	Max	Unit	Note
Accuracy of the measured SENT voltage	U_{mea}	± 0.8	± 1.0	% of FSV 20 V	In range of 3 V ... 19 V
Aging of the measured SENT voltages	U_{A-meas}		± 0.1	%/year	In range of 3 V ... 19 V
Resolution of the measured voltages		10 19,53		Bit mV/LSB	0 ... 1023

Generation of the supply/data voltages (0 V... 20 V)

Measurement	Symbol	Type	Max	Unit	Note
Accuracy of the generated voltage	U_{mea}	± 0.8	± 1.0	% of FSV 20 V	In range of 3 V ... 19 V
Aging of the generated voltages	U_{A-meas}		± 0.1	% of FSV 20 V/year	In range of 3 V ... 19 V
Resolution of the generated voltages		8 78,43		Bit mV/LSB	0 ... 255

Measurement of the currents (0 mA ... 100 mA)

Measurement	Symbol	Type	Max	Unit	Note
Accuracy of the measured supply current	I_{mea}	± 0.30	± 0.32	% of FSV 100 mA	In the range of 1 mA ... 50 mA
		± 0.55	± 0.60	% of FSV 100 mA	In the range of 1 mA ... 93 mA
Aging of the measured supply current	I_{A-meas}		± 0.1	% of FSV /year	In the range of 1 mA ... 93 mA
Resolution of the measured supply current		10 97,8		Bit μA /LSB	0 ... 1023

Generation of the currents (0 mA ... 100 mA)

Measurement	Symbol	Type	Max	Unit	Note
Accuracy of the generated voltage	I_{mea}	± 0.70	± 0.80	% of FSV 100 mA	In the range of 1 mA ... 93 mA
Aging of the generated voltages	I_{A-meas}		± 0.1	% of FSV 100 mA/year	In the range of 1 mA ... 93 mA
Resolution of the generated voltages		8 392,2		Bit μA /LSB	0 ... 255

SENT-Simulyzer operating instructions

Measurements of the 4x analog inputs (-10 V ... +10 V, 100k ohm, 250k samples/s)

Measurement	Symbol	Type	Max	Unit	Note
Accuracy of the measured voltage	U_{mea}	± 0.8	± 1.0	% of FSV 20 V	
Aging of the measured voltage	$U_{\text{A-meas}}$		± 0.05	%/year	
Resolution of the measured voltage		12		Bit	0 ... 4095
		4.88		mV/LSB	

Generation of the analog output voltage (0 V ... +5 V)

Measurement	Symbol	Type	Max	Unit	Note
Accuracy of the generated voltage	U_{mea}	± 0.8	± 1.0	% of FSV 5 V	
Aging of the generated voltage	$U_{\text{A-meas}}$		± 0.05	%/year	
Resolution of the generated voltage		12		Bit	0 ... 4095
		1.22		mV/LSB	

Tab. 9 Measurement accuracies

8 Transportation and storage

8.1 Transportation

 CAUTION	<p>Risk of crushing by the product housing. The Simulyzer may cause crushing injuries to the body and limbs if it falls over.</p> <ul style="list-style-type: none"> ➔ Transport the Simulyzer safely at all times. ➔ Place Simulyzer on a flat surface. ➔ Ensure sufficient distance from falling edges.
--	---

The Simulyzer must be transported such that it is protected against impacts and falls.

8.2 Storage

The Simulyzer must be stored in dry condition.

SENT-Simulyzer operating instructions

9 Installation and commissioning

9.1 Installation

Place the Simulyzer on a flat surface, a sufficient distance away from falling edges.

9.2 Commissioning

CAUTION

Risk of crushing by the product housing.

The Simulyzer may cause crushing injuries to the body and limbs if it falls over.

- ➔ Place Simulyzer on a flat surface.
- ➔ Ensure sufficient distance from falling edges.

NOTICE

The technical data in section 6 must be observed.

SENT-Simulyzer operating instructions

12 Assistance in the event of faults

Several potential faults can be remedied independently using the following table.

Fault	Cause	Remedy
Status display does not light up.	External power supply is not connected or fuse faulty.	Check power supply; send in Simulyzer if fuse is blown.
<u>Status display 1</u> Online – status: off Power – status: lights up	Problems with the FPGA	Send in device
<u>Status display 1</u> Online – status: lights up Power – status: lights up -> offline mode is displayed in the software.	Incorrect software downloaded or opened.	Download or open the right software from the website
<u>Status display 1</u> Online – status: lights up Power – status: lights up -> device is not recognized.	Driver not installed.	Open Windows Device Manager and install driver.

Tab. 10 Troubleshooting and remedy

If the measures listed above do not remedy the fault, contact Seskion:

Tel.: +49 (0) 7 11 / 99 05 814

E-mail: support@seskion.de

SENT-Simulyzer operating instructions

13 Disposal

Individual components can be disposed of in the normal recycling process, taking into consideration the relevant valid national regulations.

13.1 Recycling

The products can largely be recycled thanks to the high metal content. In order to ensure optimal metal recovery, they must be disassembled into individual assemblies. Metals contained in the electrical and electronic assemblies can also be recovered by means of a special separation process.

13.2 Significant components

In essence, the Simulyzer comprises the following constituents:

- Steel, stainless steel, aluminum, copper, brass
- Plastics, insulating and composite materials
- Electronic components

Plastic parts of the products may contain flame retardants. Plastic parts are marked according to EN ISO 1043-1:2011 + A1:2016 and, if necessary, must be recycled or disposed of separately according to the relevant statutory provisions.

13.3 Packaging

Seskion packaging materials do not contain any problematic substances and can easily be recycled.

The following materials are used as packaging materials:

- Cardboard
- Styrofoam
- Bubble wrap
- Plastic packaging

13.4 Disposal by the manufacturer

Products manufactured by Seskion can be returned to Seskion for disposal. The products must be delivered in suitable packaging free of charge to the following address:

Seskion GmbH
Karlsruherstraße 11/1
70771 Leinfelden-Echterdingen, Germany

SENT-Simulyzer operating instructions

14 Appendix

14.1 Service address

Seskion GmbH
Karlsruherstraße 11/1
70771 Leinfelden-Echterdingen, Germany

E-mail: info@seskion.de

Telephone: +49 (0) 7 11 / 99 05 814

14.2 Spare and wearing parts

The Simulyzer does not have any spare and wearing parts.

14.3 Declaration of conformity

The declaration of conformity for the Simulyzer can be accessed at:

https://www.seskion.de/wp-content/uploads/2023/10/CE_Konform_SENT-Simulyzer.pdf